

Propeller Assembly

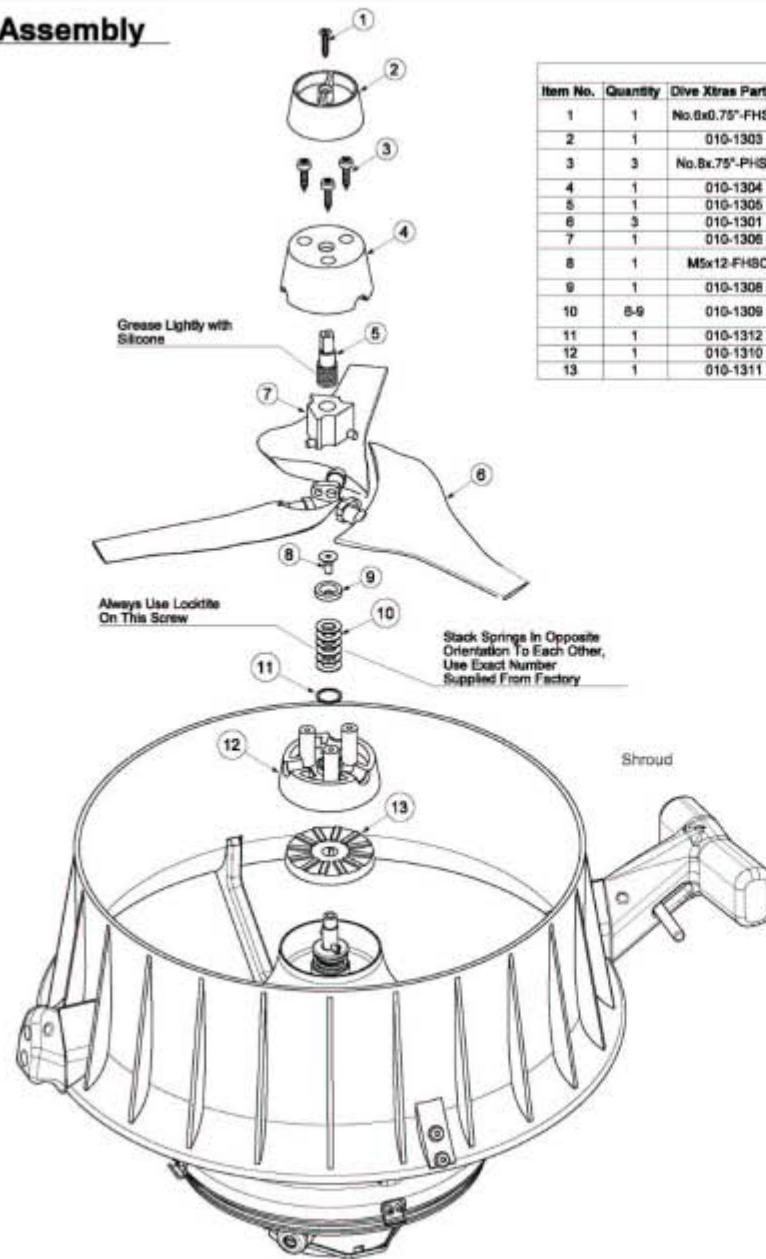

Propeller Assembly

Rev.	Description	Date
1	New Release	3/9/05



Propeller Assembly				
Item No.	Quantity	Dive Xtras Part No.	Oceanic Part No.	Description
1	1	No. 6x0.75"-FHMSMS	MAKO-712863	No. 6 x 0.75" Flat Head Phillips Sheet Metal Screw 316 SS
2	1	010-1303	MAKO-712857-01	Knob, Variable Pitch.
3	3	No. 8x.75"-PHMSMS	MAKO-712932	No. 8 x 0.75" Pan Head Phillips Sheet Metal Screw 316 SS
4	1	010-1304	MAKO-712860	Hub, Outer, Mako.
5	1	010-1305	MAKO-712861	Shaft, Yoke, Mako.
6	3	010-1301	MAKO-712759	Blade, Propeller, Mako.
7	1	010-1308	MAKO-712862	Yoke, Prop Blade, Mako.
8	1	M5x12-FHSC6	MAKO-712866	M5 x 12 Metric Flat Head Socket Cap Screw 316 Stainless steel
9	1	010-1308	MAKO-712864	Washer, Clutch, Mako
10	8-9	010-1309	MAKO-712865	WASHER, CLUTCH SPRING, MAKO (Also www.mcmaster.com PN 9713K06)
11	1	010-1312	MAKO-712901	Ring, Clutch, Mako.
12	1	010-1310	MAKO-712866	Hub, Inner, Mako.
13	1	010-1311	MAKO-712867	Plate, Clutch, Mako.

Rear Seal Assembly				
Item No.	Quantity	Dive Xtras Part No.	Oceanic Part No.	Description
1	1	010-1315		Dowel pin, 0.125" Dia, 1" Long, SS
2	1	010-1314		Retaining Ring, 0.375" Dia Shaft, SS
3	1	010-1008		Seal, Shaft.

Rear Shaft Seal Detail

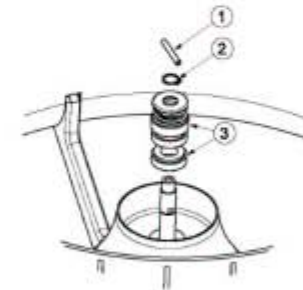

Parts

dive X

© 2004 DIVE XTRAS. ALL RIGHTS RESERVED. THIS DOCUMENT IS UNCLASSIFIED UNLESS INDICATED BY THE DOCUMENT OR THE PROPERTY OF ANY PART OF IT. AS OF THE 17th APRIL 2004, THIS DOCUMENT IS UNCLASSIFIED AND IS AVAILABLE TO ANYONE WHO WISHES TO ACCESS IT. PLEASE CONTACT THE AUTHOR FOR MORE INFORMATION.

All dimensions are in mm. Detail & finish all sharp edges.

Engineer: **Ben McGeever**

Propeller Assembly
Exploded View

Drawing No:	Rev	Sheet
xxx	1	1

Stage 1

Scooter ready to take new propeller assembly.

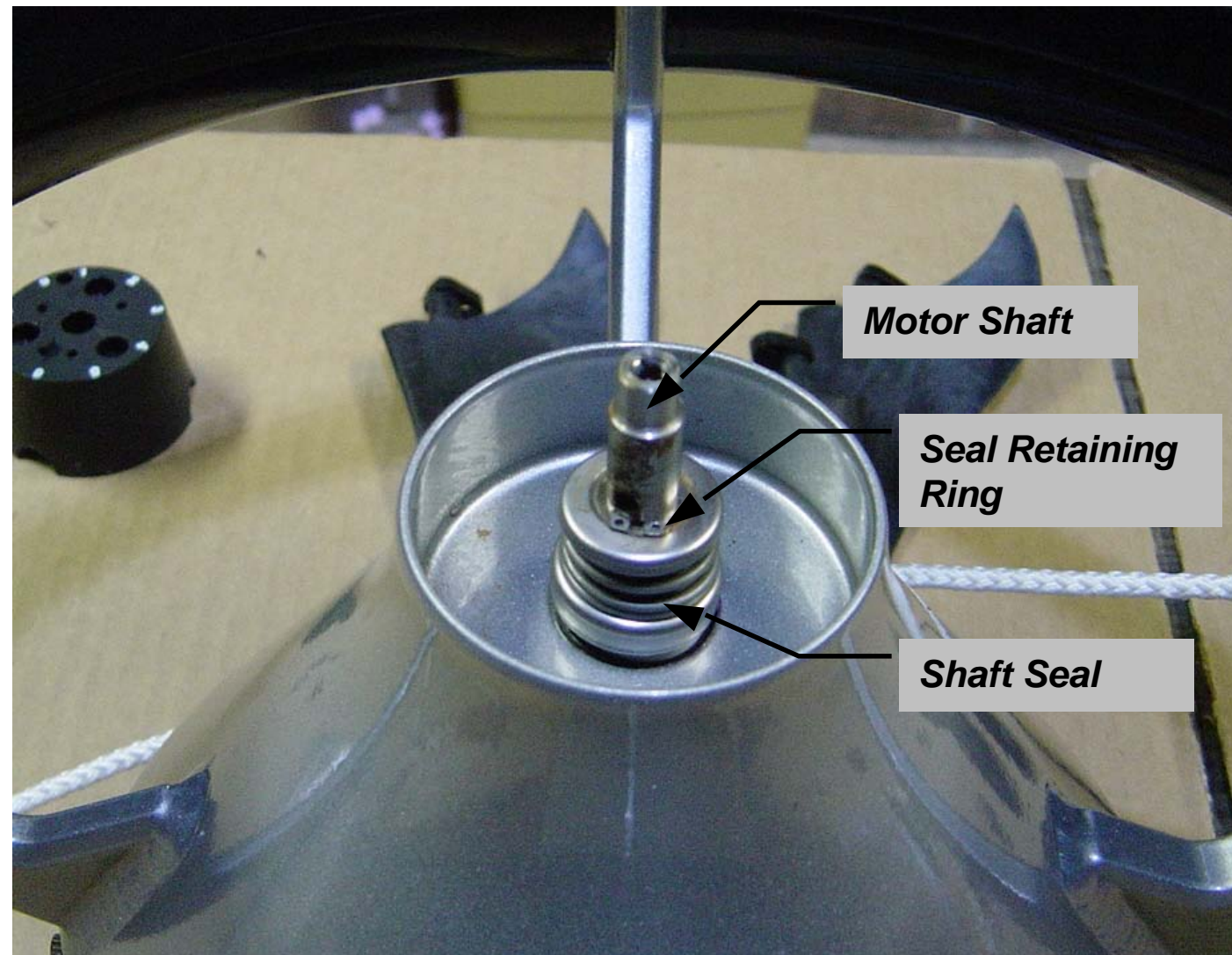

Stage 2

Fit Dowel Pin. The dowel pin transmits the torque from the motor to the prop.

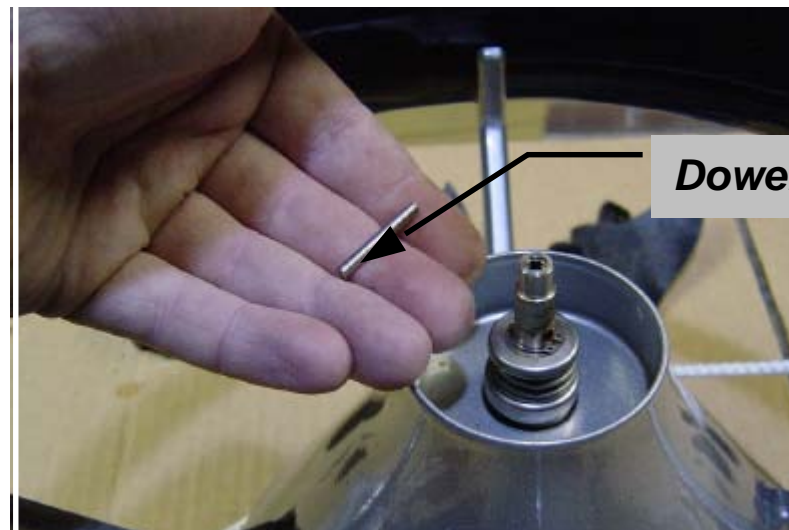

Dowel Pin

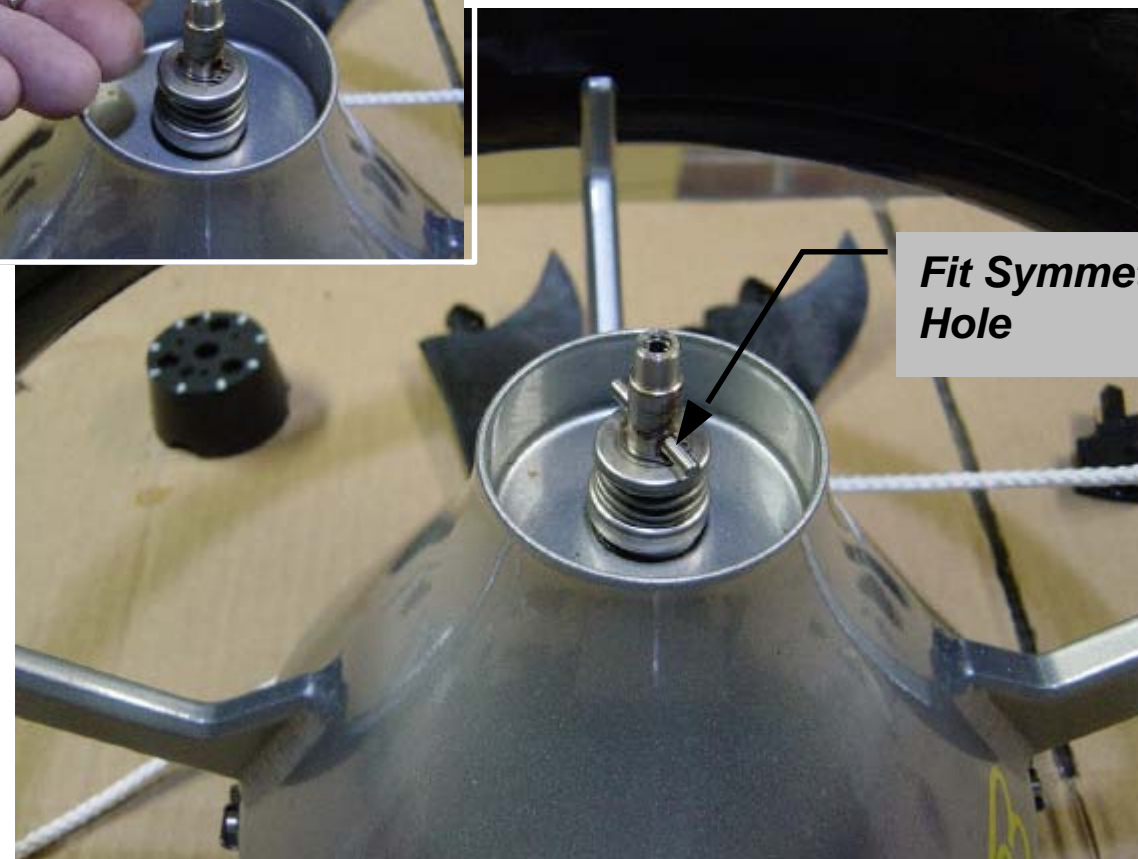

Fit Symmetrically in Hole

Stage 3

Fit Clutch Plate. Make sure the slot in the base engages with the pin.

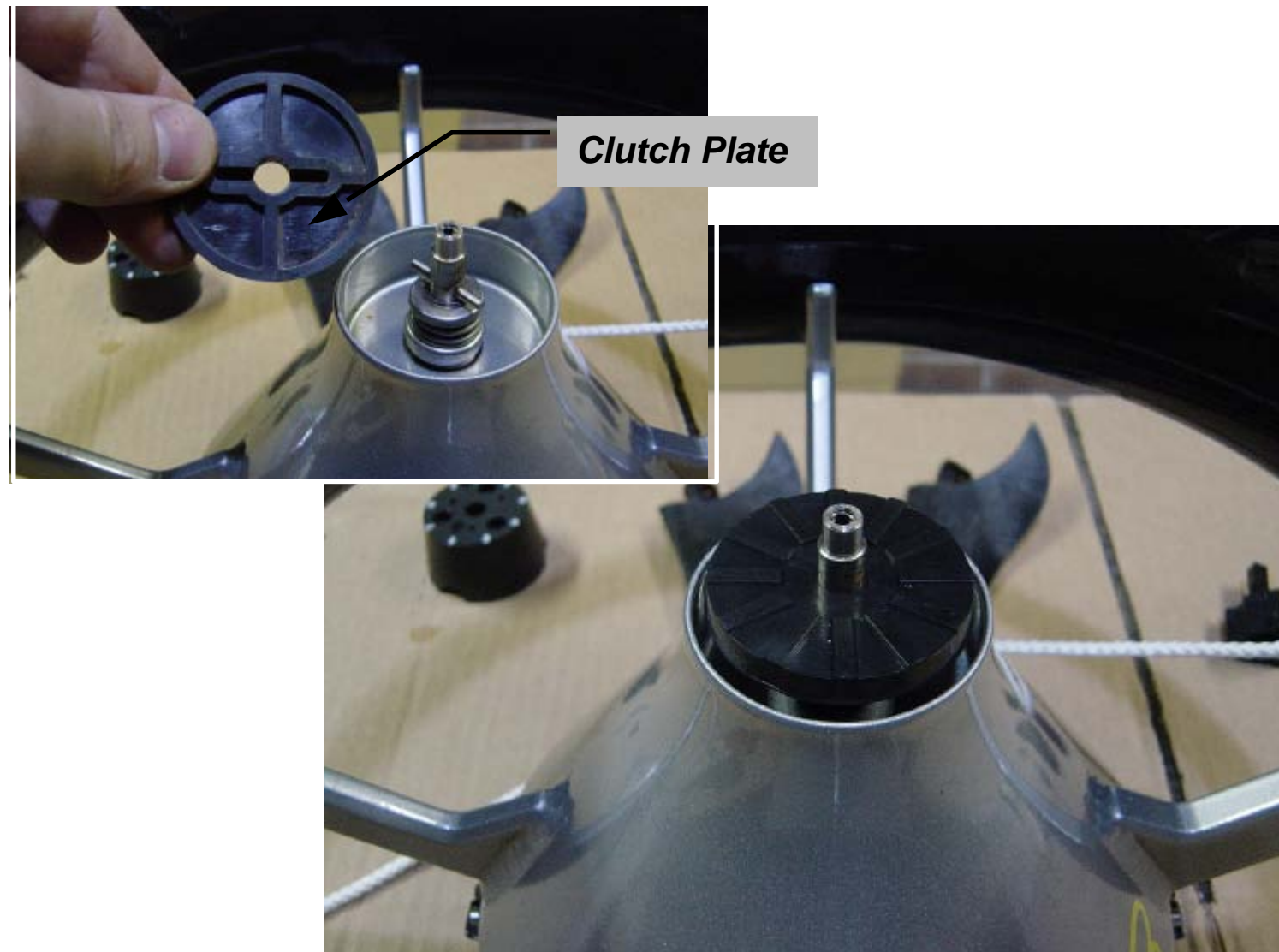

Stage 4

Fit Inner Hub. Make sure the clutch serrations engage correctly and the bottom doesn't rub on the scooter body.

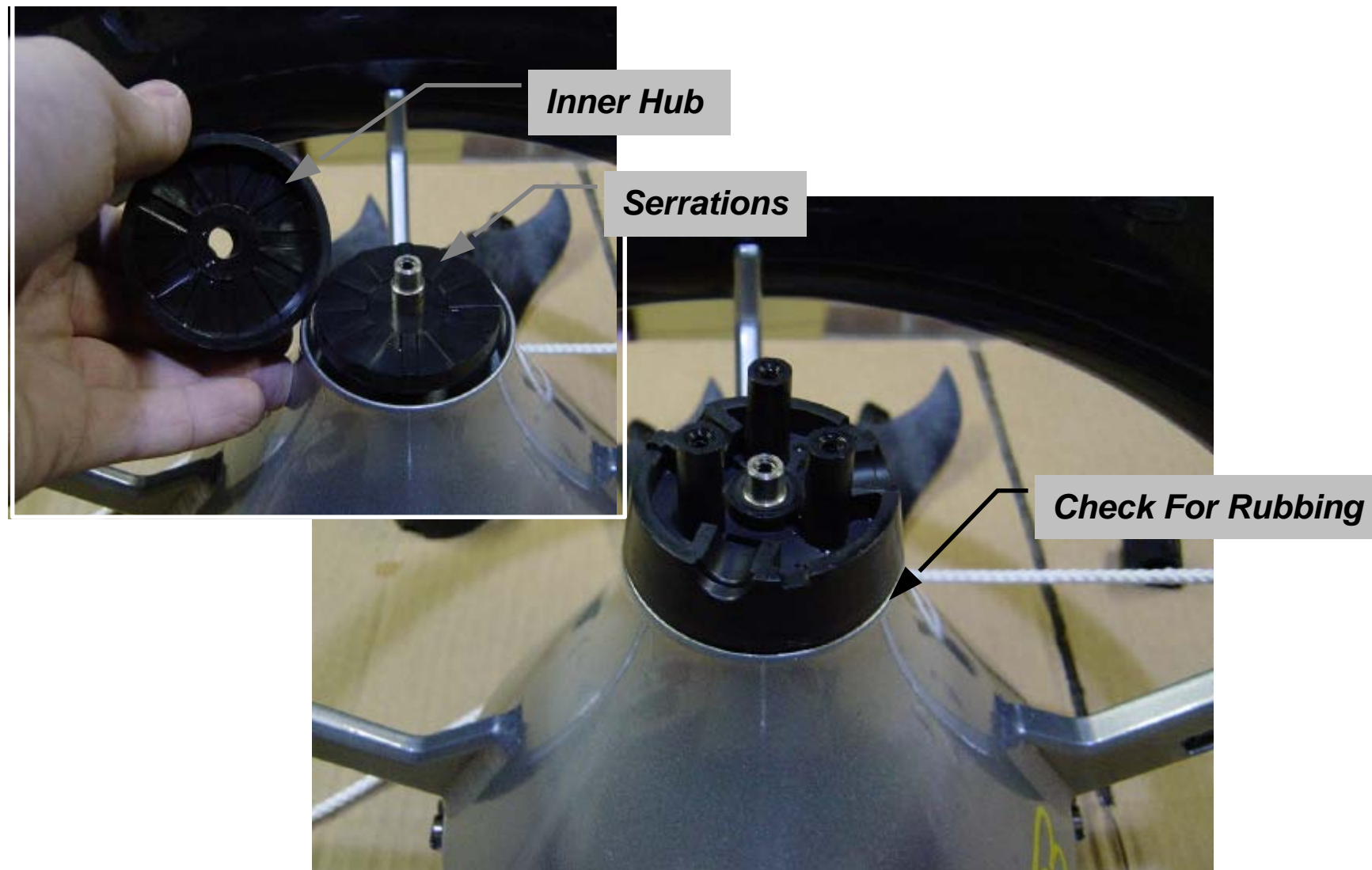

Stage 5

Fit Ring, Clutch. This prevents the springs digging into the plastic

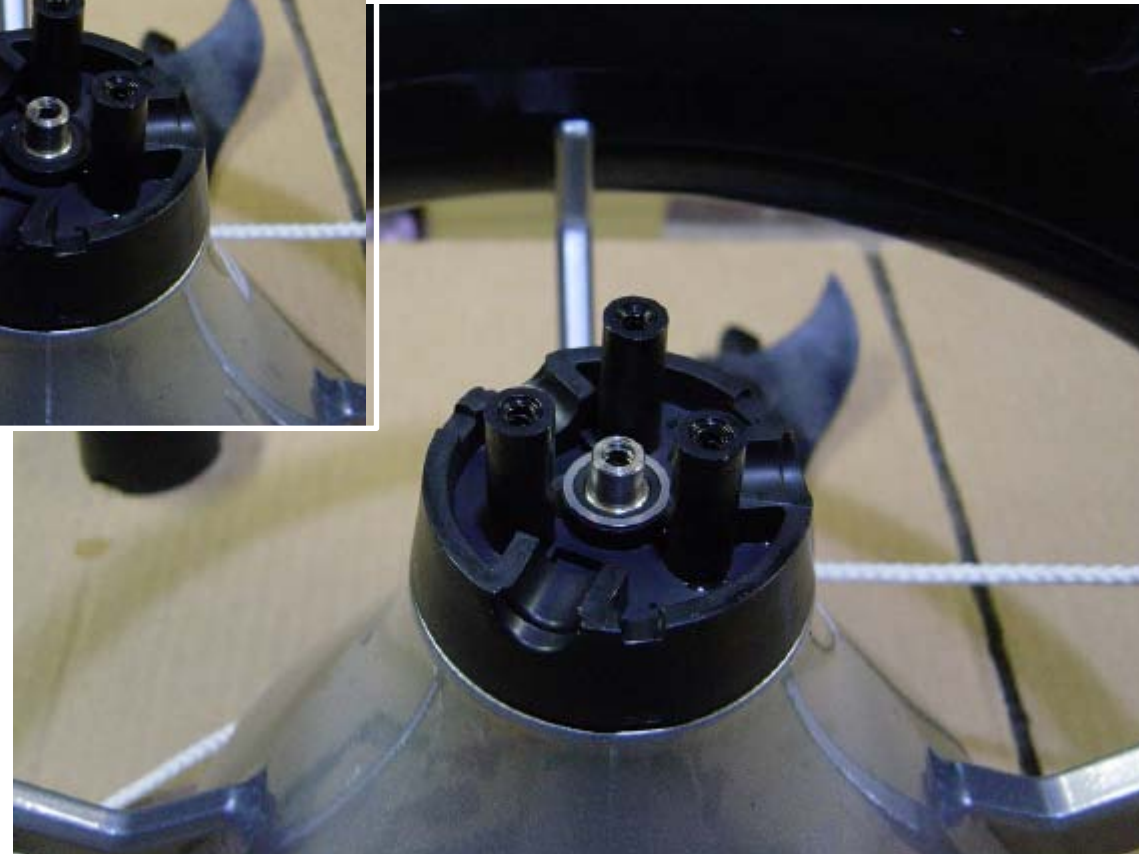
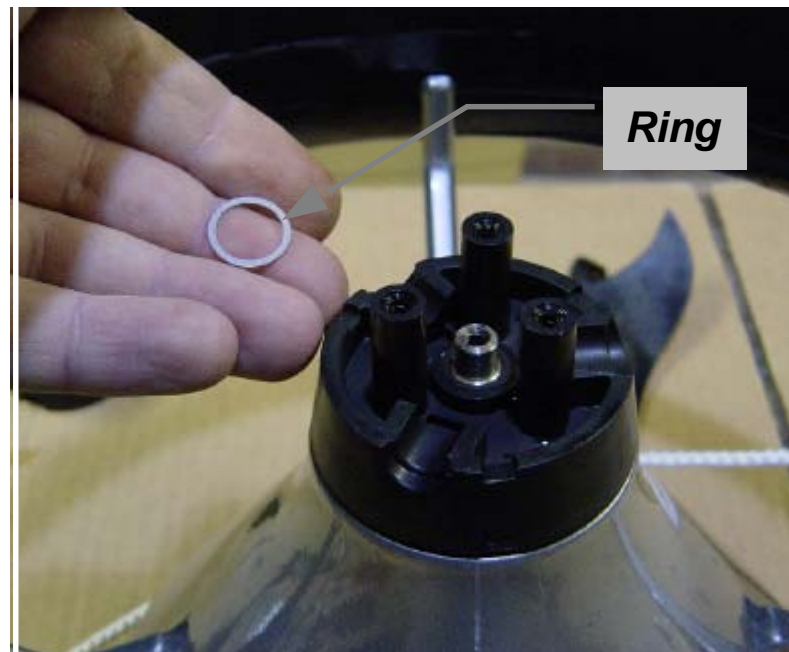

Stage 6

Fit Clutch Springs. 9 springs are normally fitted. They have a slight cup and are fitted back to back. They can be assembled prior to fitting on a screwdriver

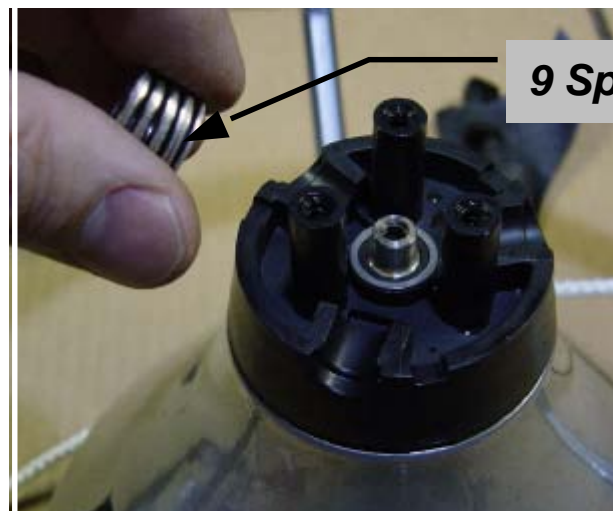

9 Springs

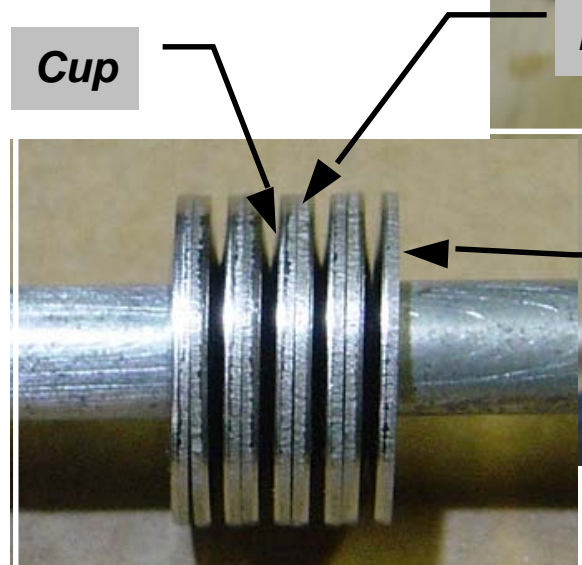

Cup

Back To Back

This End Down

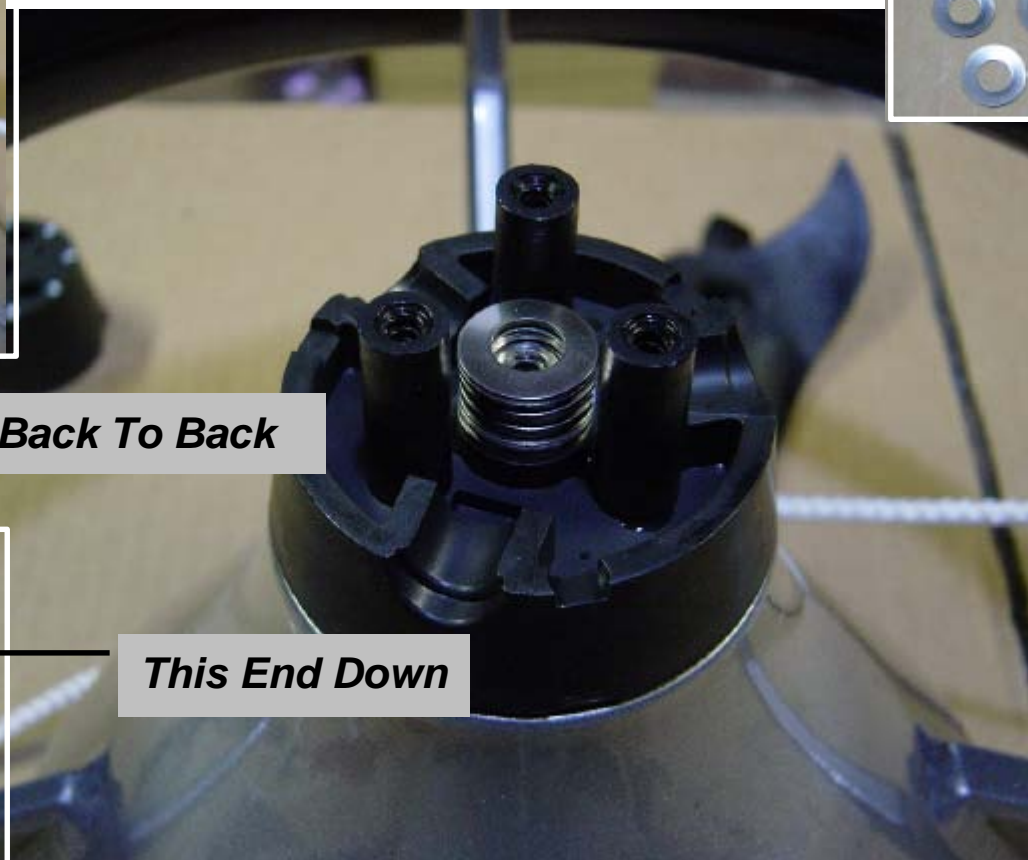

Stage 7

Fit Washer, Clutch.



Stage 8

Fit Cap Screw. Make sure to use medium strength locktite and to keep all the springs in alignment. Spring stack when compressed should be almost solid, but not quite. If gaps are large add extra springs

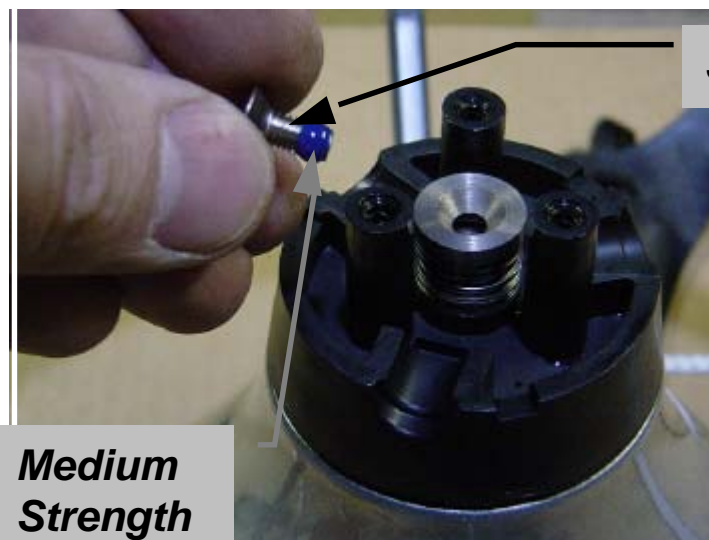

**Medium
Strength
Locktite**

Screw

**Check for gaps
which indicate
springs are not
totally
compressed**

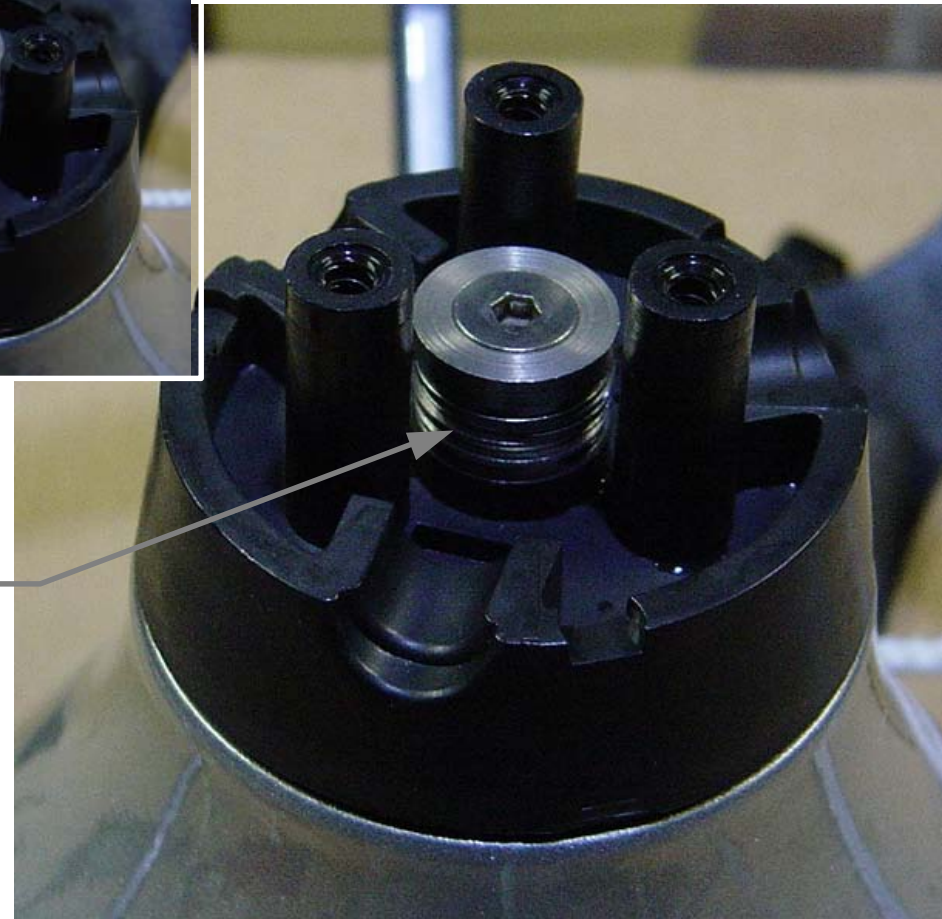

Stage 9

Fit Yoke and Shaft. Screw together prior to assembly



Yoke

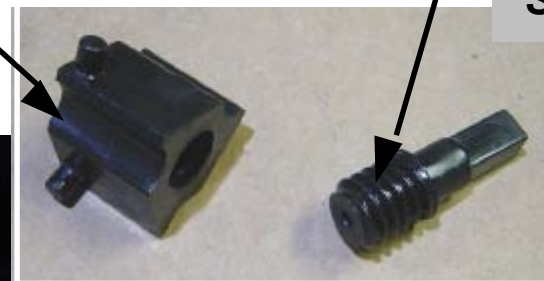

Shaft

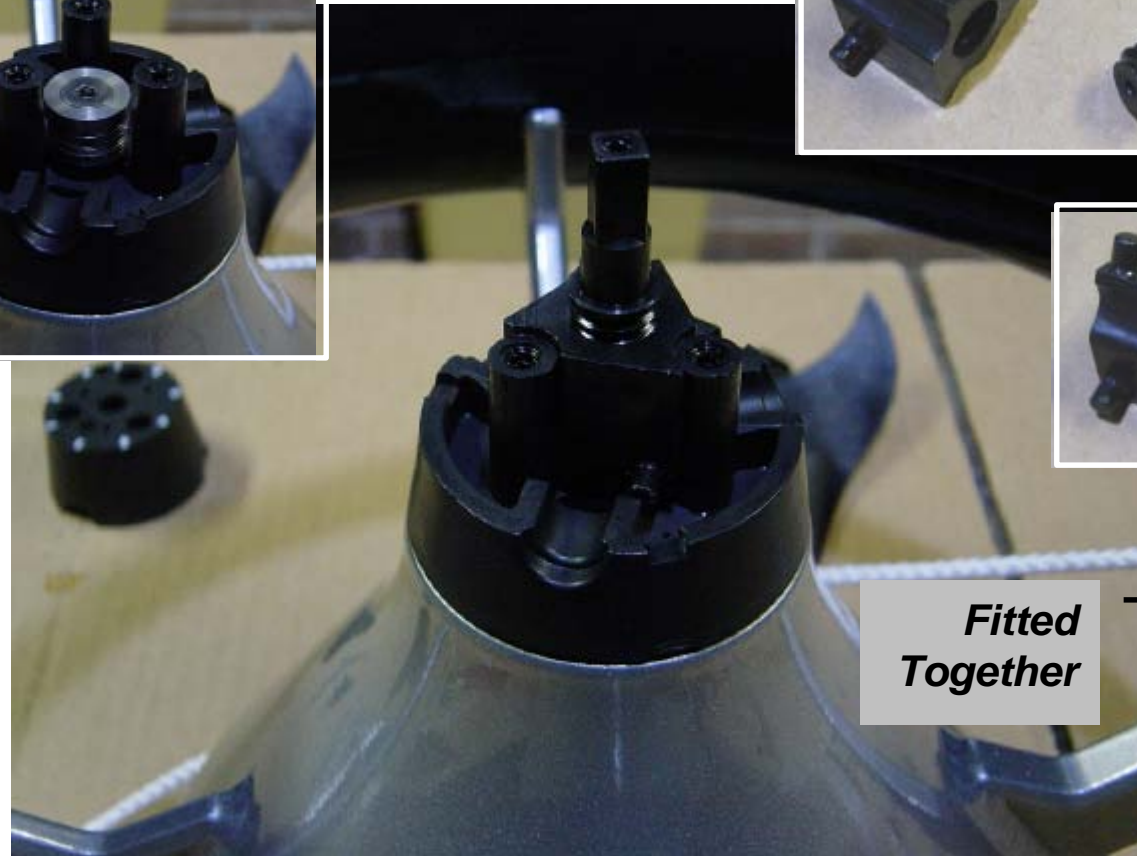

Fitted Together



Stage 10

Fit Propeller Blades

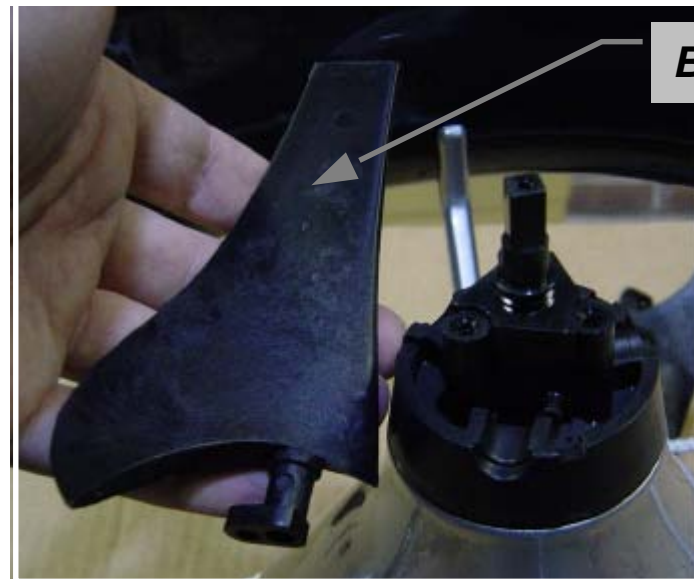

Blade

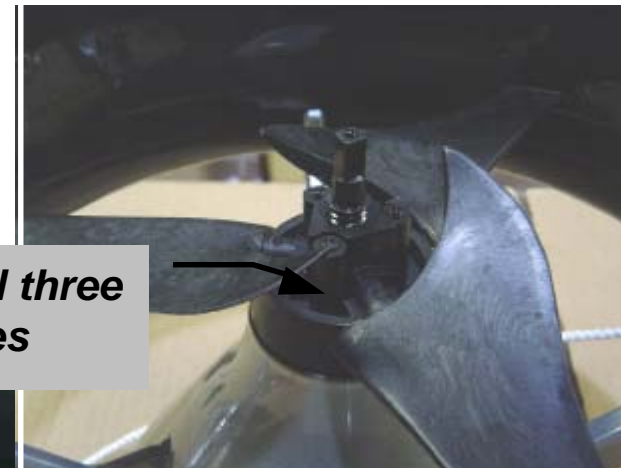

Fit all three blades

Match hole on prop with pin on yoke

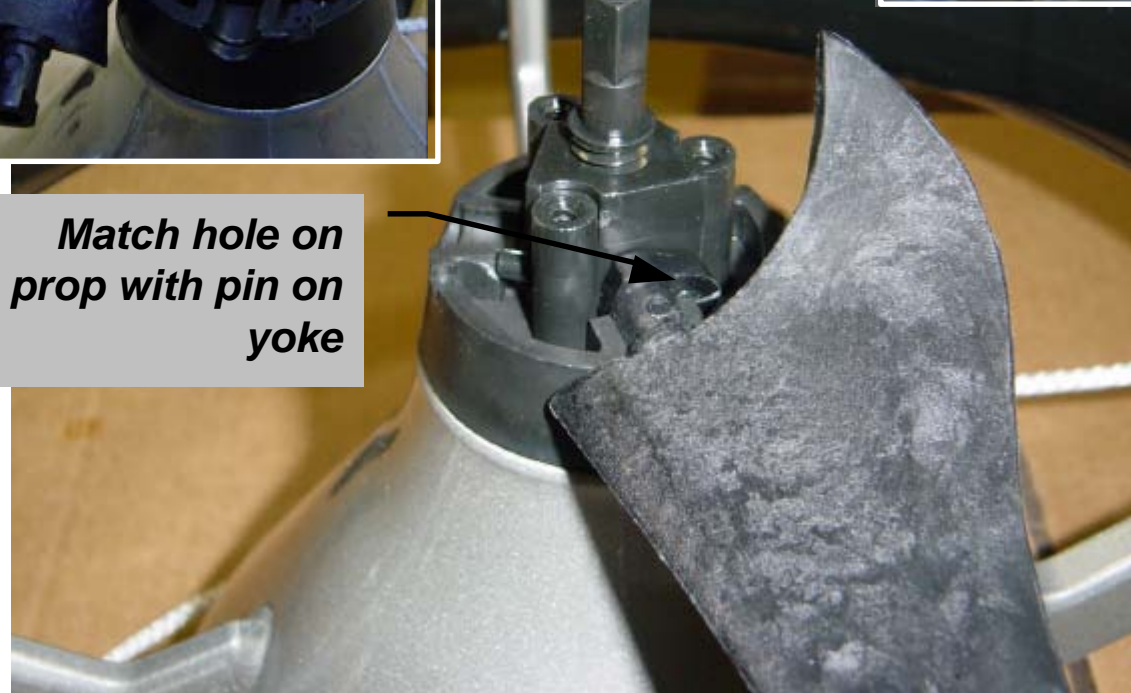

Stage 11

Fit Hub, Outer. Make sure it screws down fully and there is no gap at the base.

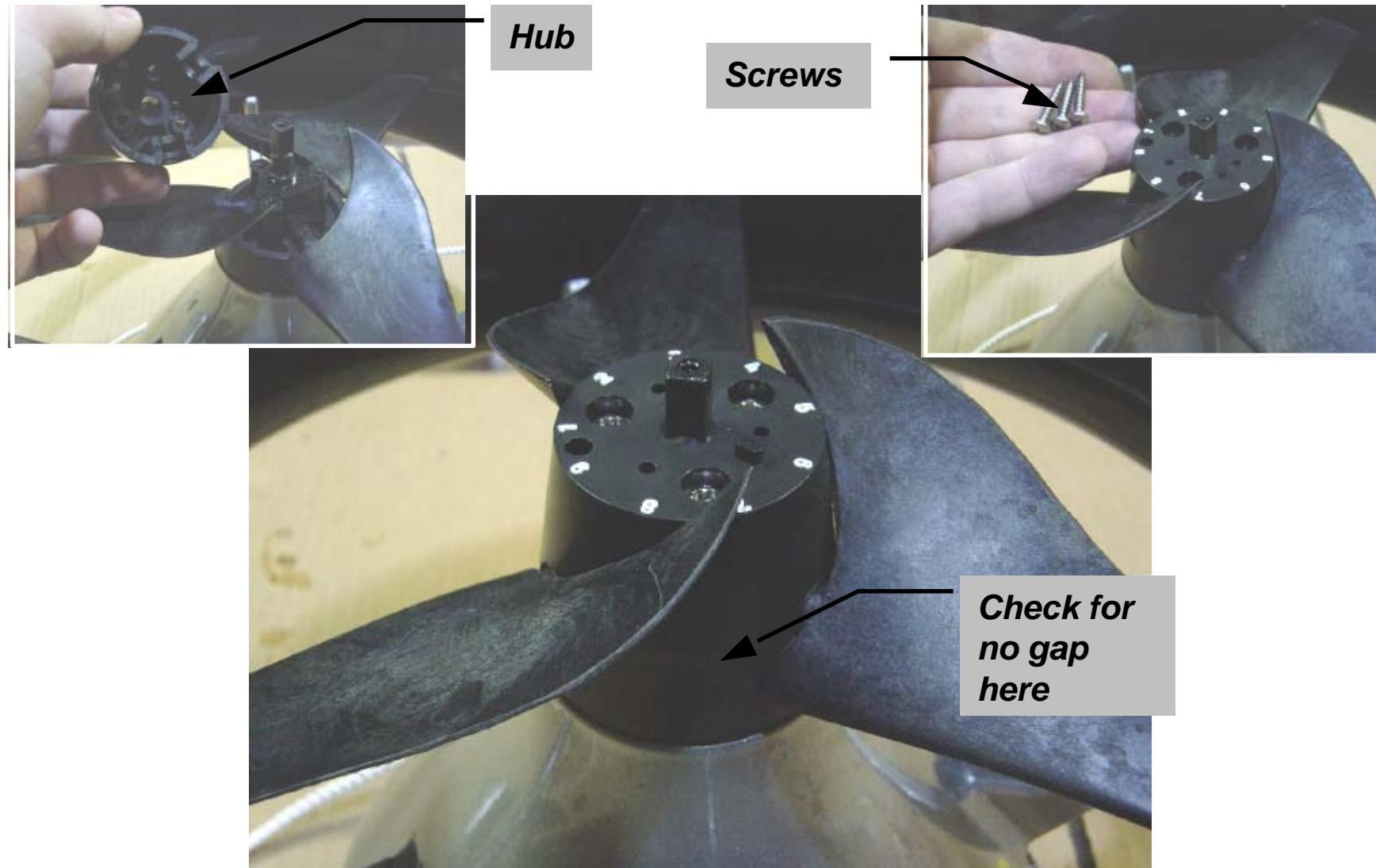

Stage 12

Fit Knob, Variable Pitch . First turn the square end of the shaft until the clearance between the hub and the propeller is about 1mm. Then fit the knob in position number "9"

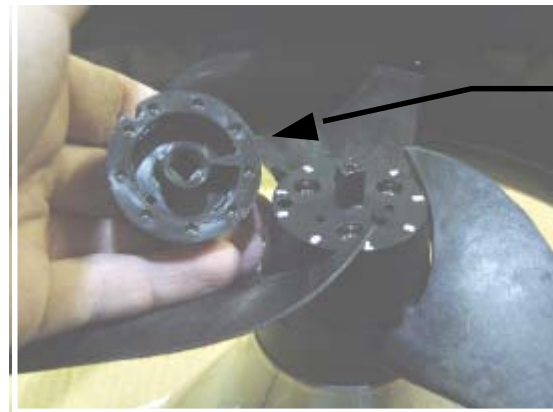

Knob

Screws

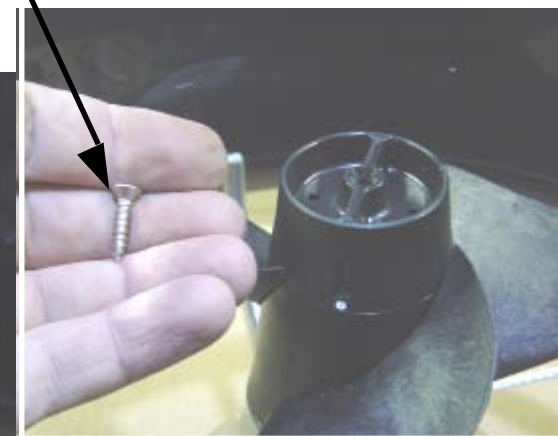

Number "9"

Check Clearance Here

